

# 1800 BUILDER S3

THE BUILDER MODEL IS A FULLY ENCLOSED UNIT. COMPRISED OF 5 SEPARATE COMPARTMENTS, 2 ACCESSED FROM EACH SIDE AND 1 FROM THE REAR. ALL INTERNAL WALLS CAN BE CUSTOMISED. 300KG RATED LADDER RACKS AND 1 ADJUSTABLE SHELF PER SIDE COMPARTMENT FITTED AS STANDARD. THE UNIT COMES POWDERCOATED IN A RANGE OF COLOURS. IT IS A REMOVABLE BODY AND CLAMPS TO YOUR ALUMINIUM OR STEEL TRAY WITH THE TSB CLAMPING SYSTEM (INCL).

- SUITABLE FOR ALL 1 TONNE DUAL/CREW CAB VEHICLES.
- LIGHT WEIGHT, RUST RESISTANT ALUMINIUM CONSTRUCTION.

## OPTIONS:

- |                         |                                   |
|-------------------------|-----------------------------------|
| ADDITIONAL SHELVING     | ADJUSTABLE GAS BOTTLE MOUNTS      |
| SLIDE OUT DRAWERS       | VENTED COMPARTMENTS               |
| SLIDE OUT WORKBENCH     | ROTARY VENTS                      |
| REMOTE CENTRAL LOCKING  | RUBBER OR CARPET FLOOR/SHELF MATS |
| REVERSING CAMERA        | PIVOTING SPARE WHEEL MOUNT        |
| UNDERSIDE TOOLBOXES     | COMPRESSOR MANIFOLD               |
| UNDERSIDE WASH STATION  | EMERGENCY LIGHTING/ FLOOD LIGHTS  |
| REAR SWING OUT VICE     | JACKS (SET OF 4)                  |
| INTERNAL SLIDE OUT VICE |                                   |
| LADDER RACK EXTENTION   |                                   |

\*REFER TO WEBSITE FOR FULL LIST OF ACCESSORIES & PRICES

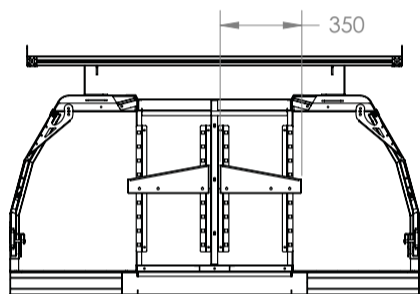
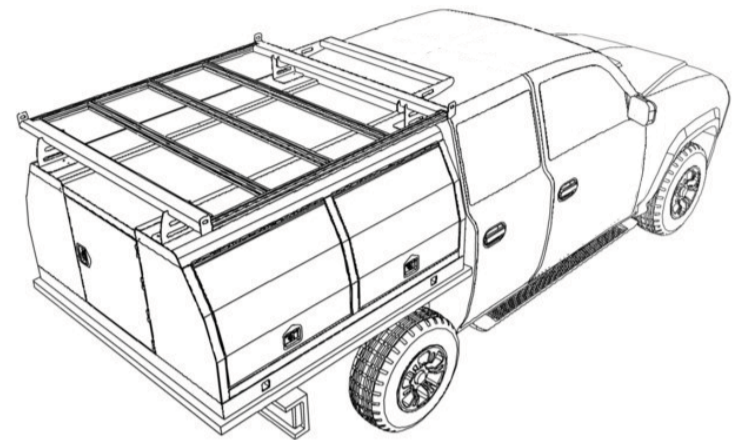

STANDARD SHELVING E-E  
SECTION VIEW

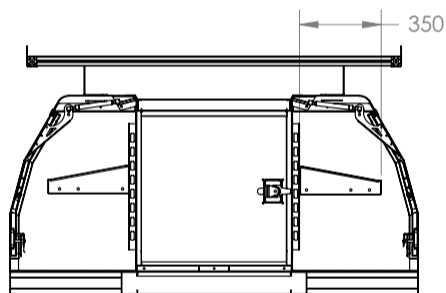

STANDARD SHELVING F-F  
SECTION VIEW

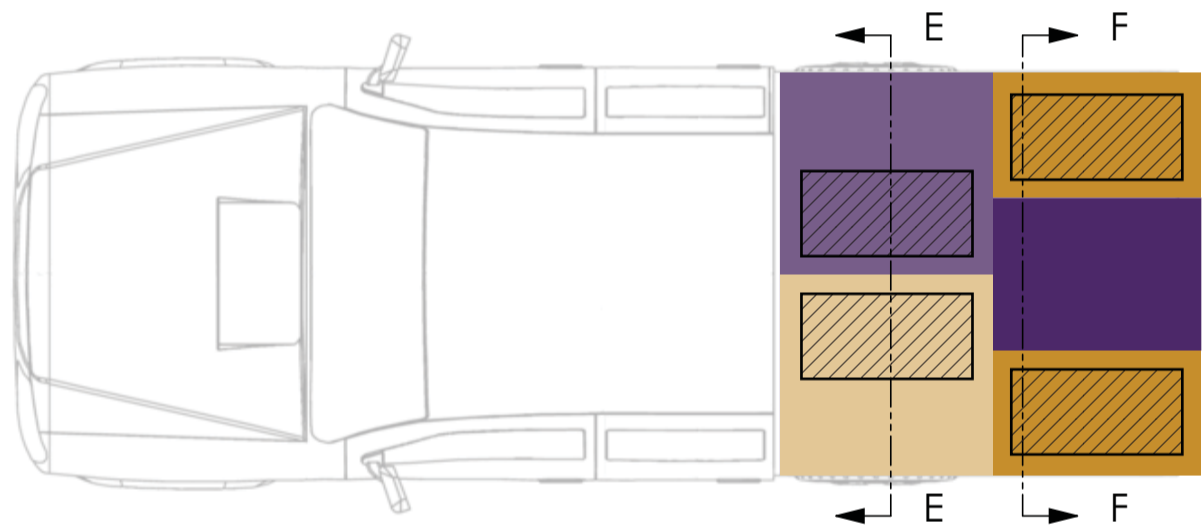
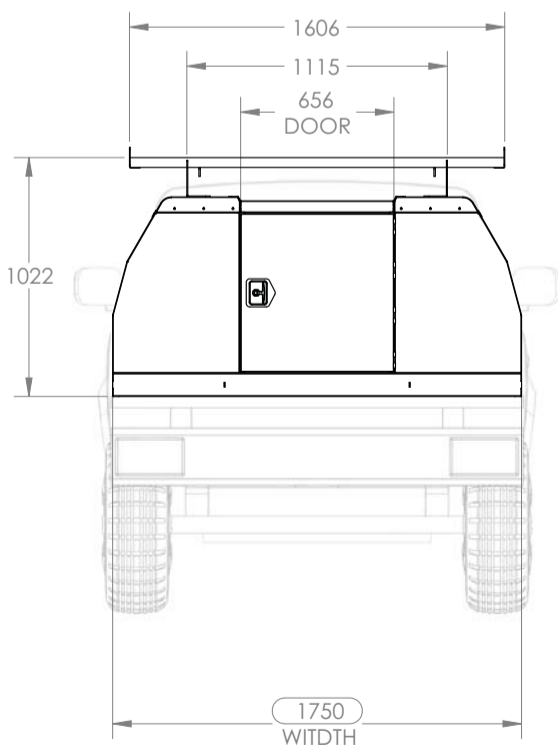

FLOOR PLAN G-G

- COMPARTMENT 1
- COMPARTMENT 2
- COMPARTMENT 3
- COMPARTMENT 4
- ▨ STANDARD SHELF
- ▨ OPTIONAL WALLS

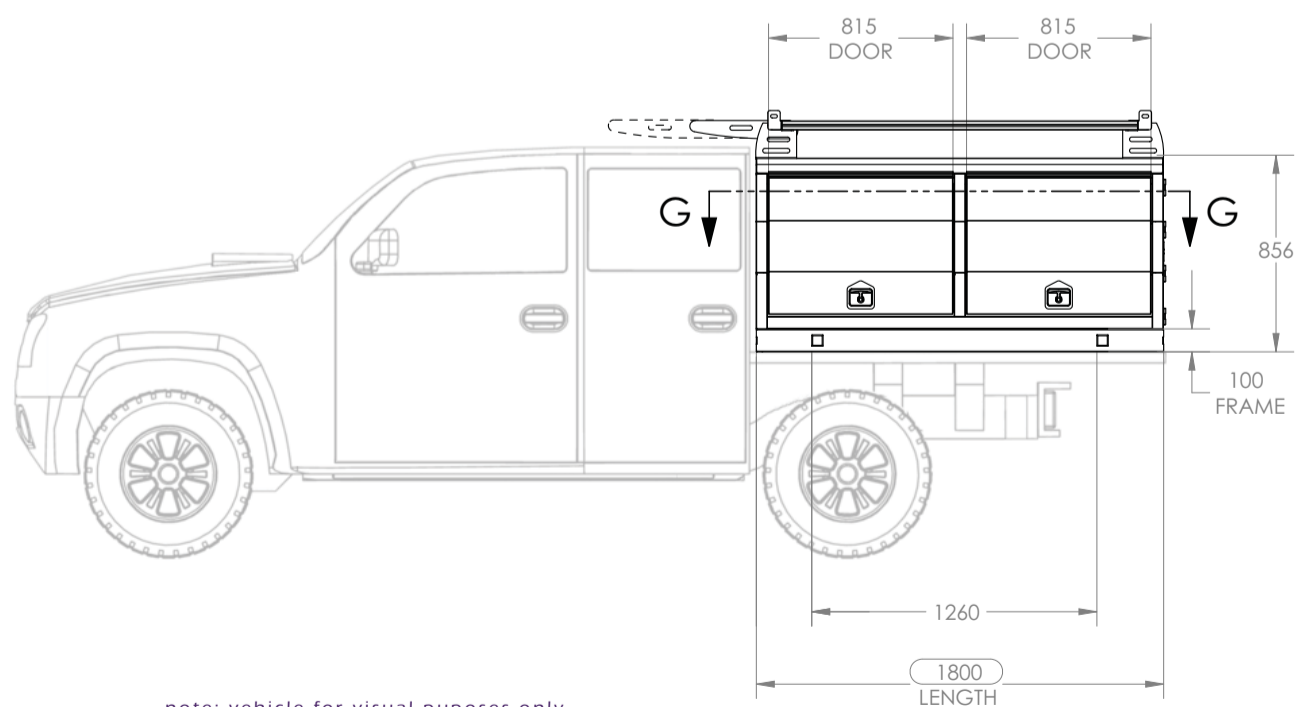

note: vehicle for visual puposes only



## TRADE SERVICE BODY

28 Quality Drive, Dandenong, Victoria, 3175  
ph 1300 131 574 Email info@tsb.net.au  
[www.tsb.net.au](http://www.tsb.net.au)