

2100 LT-SERVICE S3 SHOVEL

THE LT SERVICE SHOVEL MODEL IS A FULLY ENCLOSED UNIT. IT IS COMPRISED OF 2 SEPARATE COMPARTMENTS AND 1 LARGE T-SECTION OPEN SPACE. ALL INTERNAL WALLS CAN BE CUSTOMISED. 300KG RATED LADDER RACKS, SHOVEL DRAWER AND 2 ADJUSTABLE SHELVES PER COMPARTMENT FITTED AS STANDARD. THE UNIT COMES POWDERCOATED IN A RANGE OF COLOURS. IT IS A REMOVABLE BODY AND CLAMPS TO YOUR ALUMINIUM OR STEEL TRAY WITH THE TSB CLAMPING SYSTEM (INCL).

- SUITABLE FOR ALL 1 TONNE SPACE/EXTRA CAB VEHICLES.
- LIGHT WEIGHT, RUST RESISTANT ALUMINIUM CONSTRUCTION.

OPTIONS:

- | | |
|-------------------------|-----------------------------------|
| ADDITIONAL SHELVING | INTERNAL SLIDE OUT VICE |
| SLIDE OUT DRAWERS | ADJUSTABLE GAS BOTTLE MOUNTS |
| SLIDE OUT WORKBENCH | VENTED COMPARTMENTS |
| REMOTE CENTRAL LOCKING | ROTARY VENTS |
| REVERSING CAMERA | RUBBER OR CARPET FLOOR/SHELF MATS |
| UNDERSIDE TOOLBOXES | PIVOTING SPARE WHEEL MOUNT |
| UNDERSIDE WASH STATION | COMPRESSOR MANIFOLD |
| REAR SWING OUT VICE | EMERGENCY LIGHTING/ FLOOD LIGHTS |
| LADDER RACK INFILL BARS | BI-FOLD DOORS |
| LADDER RACK EXTENTION | JACKS (SET OF 4) |



*REFER TO WEBSITE FOR FULL LIST OF ACCESSORIES

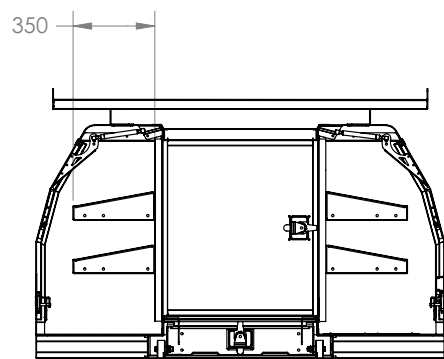

STANDARD SHELVING F-F SECTION VIEW

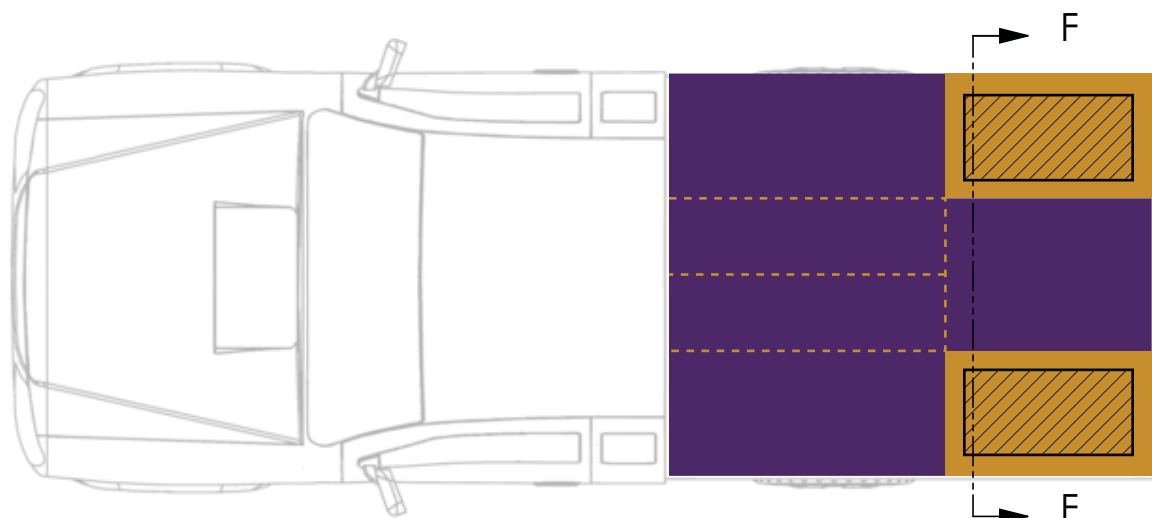

FLOOR PLAN G-G

- COMPARTMENT 1
- COMPARTMENT 2
- ▨ STANDARD SHELF
- - - OPTIONAL WALLS

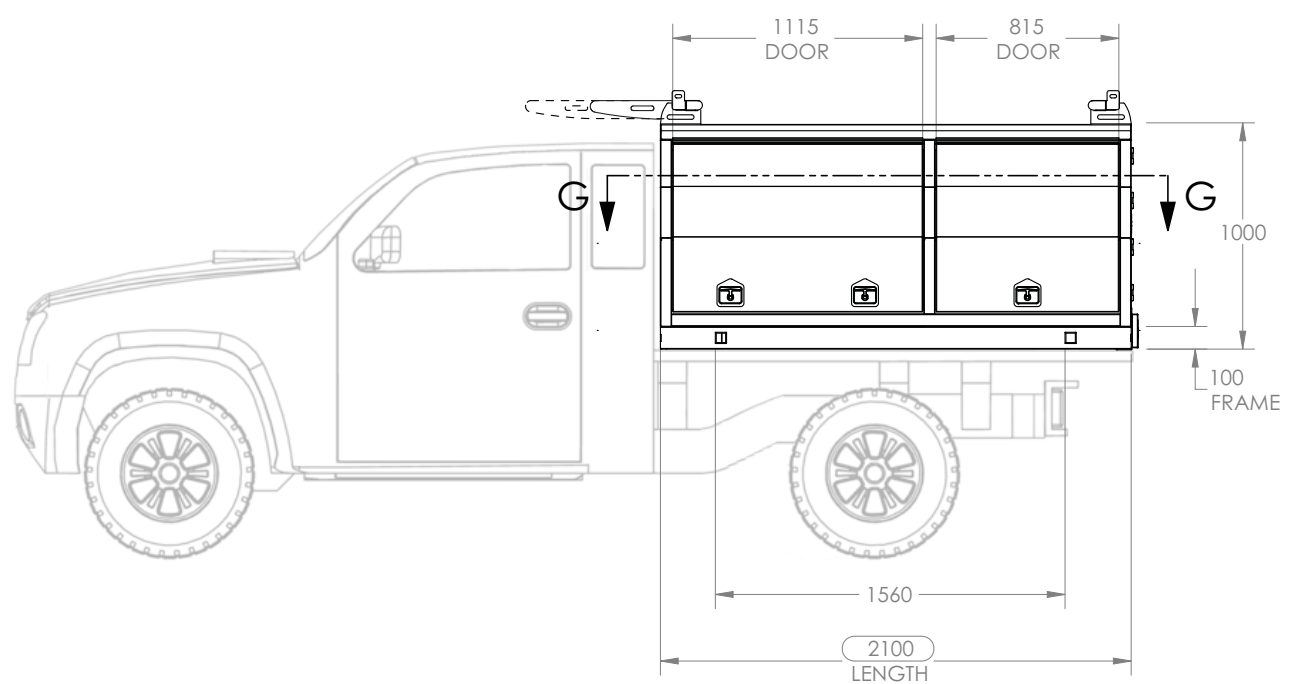
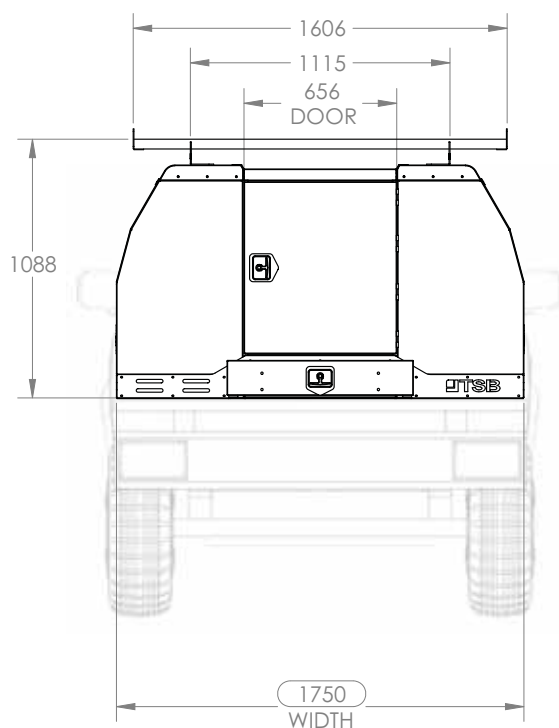

note: vehicle for visual puposes only



TRADE SERVICE BODY

28 Quality Drive, Dandenong, Victoria, 3175
 ph 1300 131 574 Email info@tsb.net.au
www.tsb.net.au