

# 2100 UTILITY S3

THE UTILITY MODEL IS COMPRISED OF 6 COMPARTMENTS, 3 ACCESSED FROM EACH SIDE, AND A 3/4 LENGTH CENTRE AISLE, THE FRONT COMPARTMENTS ARE THE FULL WIDTH OF THE TSB, WITH A CENTRE DIVIDER WALL. 300KG RATED LADDER LACKS, SHOVEL DRAWER AND 1 ADJUSTABLE SHELF PER COMPARTMENT FITTED AS STANDARD. THE UNIT COMES POWDERCOATED IN A RANGE OF COLOURS. IT IS A REMOVABLE BODY AND CLAMPS TO YOUR ALUMINIUM OR STEEL TRAY WITH THE TSB CLAMPING SYSTEM (INCL).

- SUITABLE FOR ALL 1 TONNE SPACE/EXTRA CAB VEHICLES.
- LIGHT WEIGHT, RUST RESISTANT ALUMINIUM CONSTRUCTION.

## OPTIONS:

- |                         |                                   |
|-------------------------|-----------------------------------|
| ADDITIONAL SHELVING     | LADDER RACK ROLLERS               |
| SLIDE OUT DRAWERS       | ADJUSTABLE GAS BOTTLE MOUNTS      |
| SLIDE OUT WORKBENCH     | VENTED COMPARTMENTS               |
| REMOTE CENTRAL LOCKING  | ROTARY VENTS                      |
| REVERSING CAMERA        | RUBBER OR CARPET FLOOR/SHELF MATS |
| UNDERSIDE TOOLBOXES     | CONDUIT TUBES                     |
| UNDERSIDE WASH STATION  | EMERGENCY LIGHTING/ FLOOD LIGHTS  |
| REAR SWING OUT VICE     | REAR STEP/GRAB HANDLES            |
| INTERNAL SLIDE OUT VICE | JACKS (SET OF 4)                  |
| LADDER RACK EXTENTION   |                                   |

\*REFER TO WEBSITE FOR FULL LIST OF ACCESSORIES & PRICES

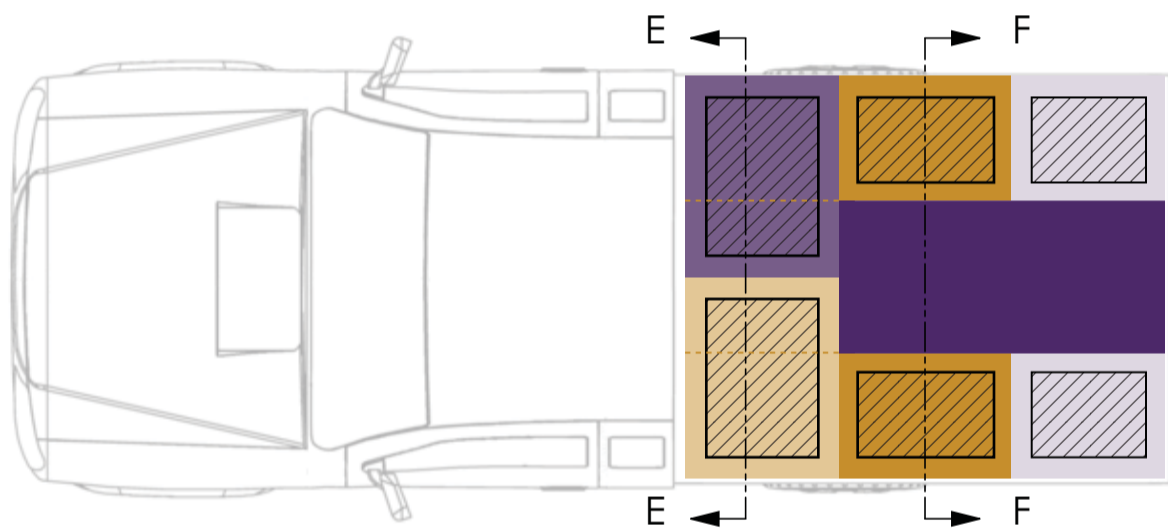
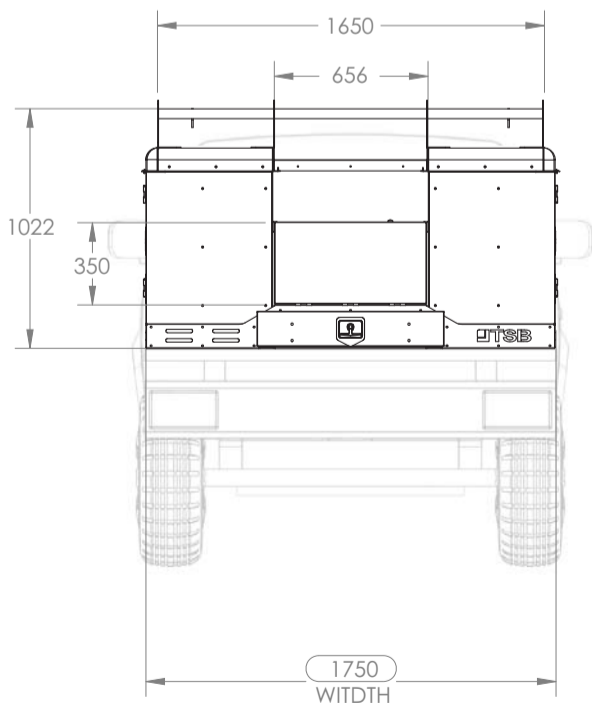
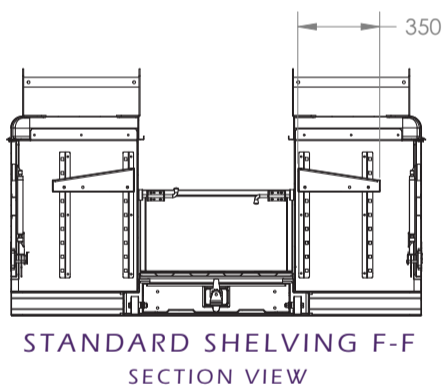
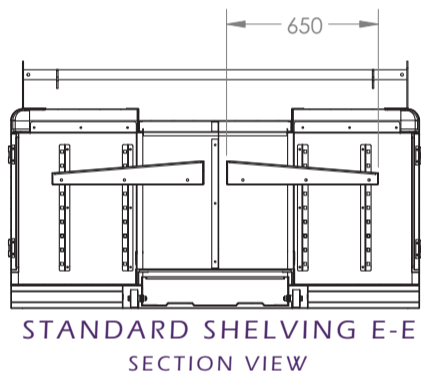
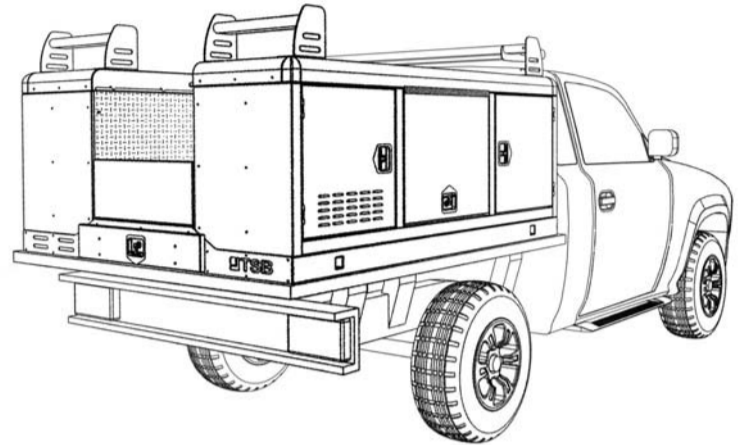

- AISLE
- COMPARTMENT 1
- COMPARTMENT 2
- COMPARTMENT 3
- COMPARTMENT 4
- ▨ STANDARD SHELF
- ▨ OPTIONAL WALLS

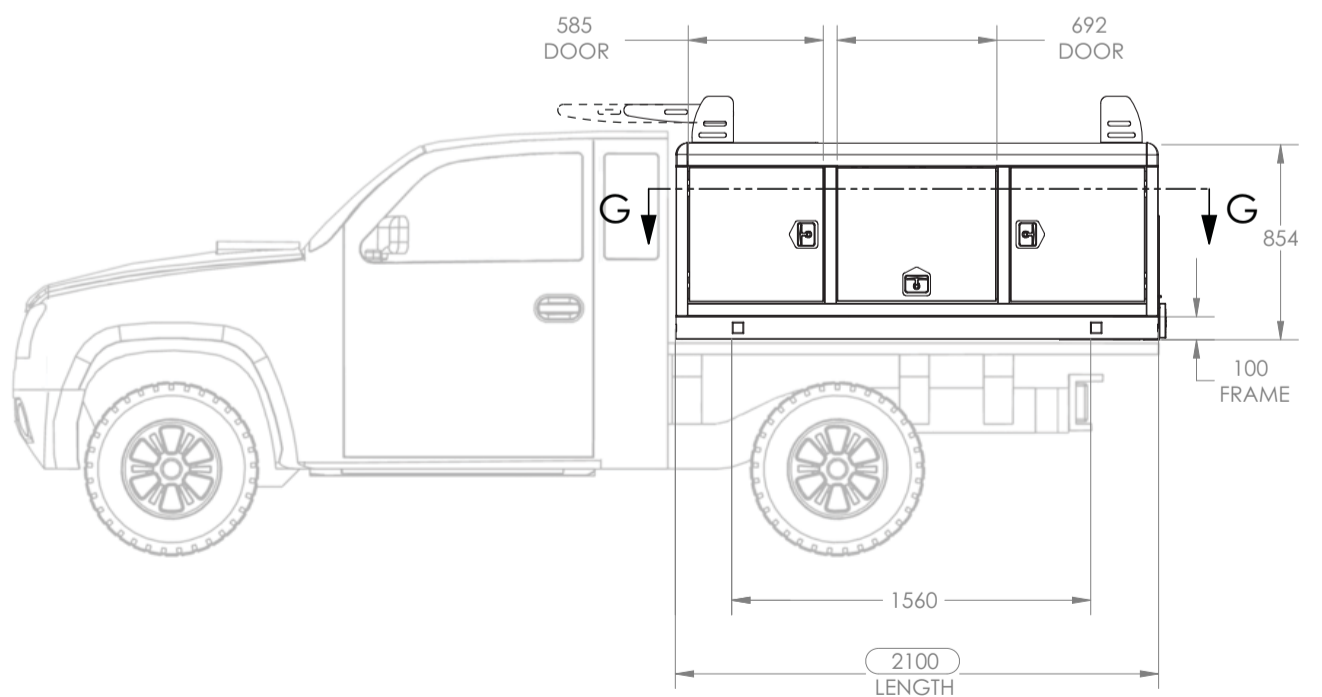

note: vehicle for visual puposes only



## TRADE SERVICE BODY

28 Quality Drive, Dandenong, Victoria, 3175  
 ph 1300 131 574 Email info@tsb.net.au  
[www.tsb.net.au](http://www.tsb.net.au)